

SERVICE BULLETIN – 01/SEPTEMBER 2009

SDN 25 - SDN 30 - SDN 35

NEW TIMER

After positive field test of hundreds ice machines we are switching from an electromechanical to a new Electronic TIMER in all our SDN Series.



The first models involved in the installation of the Electronic TIMER are the SDN 25, SDN 30 and SDN 35, so starting from the following Serial Numbers:

SDN 25 Serial Number 223063

SDN 30 Serial Number 778803

SDN 35 Serial Number 275824

has been installed a electronic timer, available under Part Number **62050700**.

New Electronic Timer is equipped with a DIP Switch and a Potentiometer, as per photo below.

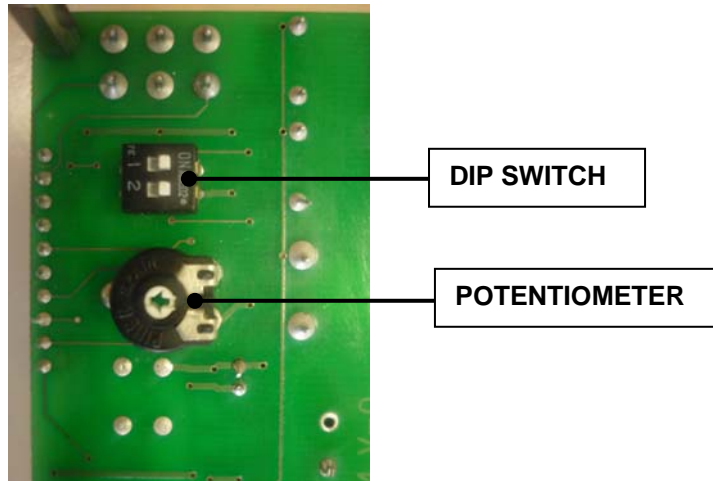

The DIP SWITCH has two switching keys (ON-OFF) which allow to change the functions as detailed herebelow:

- First DIP SWITCH Key. ON, standard position, supply power directly to the Compressor. OFF shuts-off the compressor. It replaces the previous Compressor Switch.
- Second DIP SWITCH Key. ON, 12'.Timing portion of the freezing cycle equal to 12 minutes. OFF to 8 minutes.

POTENTIOMETER used to adjust the defrost timer from 60'' min to 180'' max.

Due the different electrical connections, this new electronic Timer is NOT exchangeable with the former one used on the same models, as shown on the here below photo:

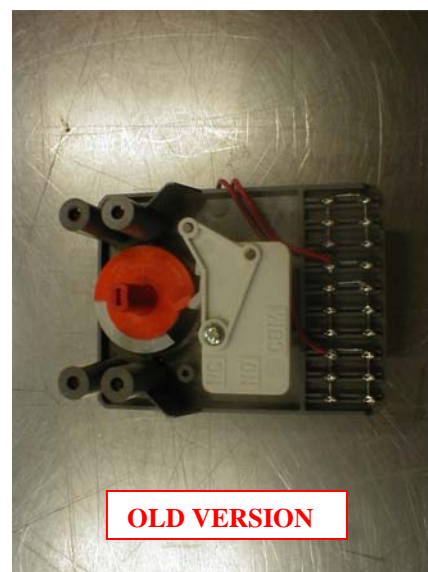

Attached you can find the layout of this new TIMER as well as the wiring diagram of the Ice Machines.

SCHEMA ELETTRICO

ELECTRICAL WIRING DIAGRAM

SDN 25/30/35/45/65/85

SCRN/SCN 35/45/65/85

00 - EMESSO

00	04629	RG	09.02.09	DATA	09.02.09	PRIMA PAGINA <i>FIRST PAGE</i>	SDN 25/30/35/45/65/85 SCRN/SCN 35/45/65/85	 FRIMONT S.p.a.	230 Vac 50/60 Hz	=			
				DISEGN.	R.GHIANI						+		
				VISTO	G.ROMAGNOLI								
REV.	MODIFICA	SG	DATA	FIRMA	APPR.	G.ROMAGNOLI	SOST. IL : 09.02.09	SOST. DA : G.ROMAGNOLI	FILE : 05057800.DWG	050578-00	00	FG. 1	
0			1			2	3	4	5	6	7	8	9

Sim.\Sym.	Sigla\Item	Funzione\Use Type	Sim.\Sym.	Sigla\Item	Funzione\Use Type	Sim.\Sym.	Sigla\Item	Funzione\Use Type
	EV1	Fan motor Ventilatore		YV3	Hot gas valve Elettrovalvola gas caldo			
	M1	Compressor Compressore						
	M2	Water pump Pompa acqua						
	SA1	Power switch Interruttore generale						
	SP1	Water pressure control Pressostato acqua						
	ST1	HI Temperature control Controllo alta temperatura						
	ST2	Bin thermostat Termostato magazzino						
	ST3	Evaporator thermostat Termostato evaporatore						
	TM1	Electronic timer Timer elettronico						
	YV1	Water condenser valve Elettrovalvola acqua condensatore						
	YV2	Water inlet valve Elettrovalvola ingresso acqua						

00 - EMESSO

00	04629	RG	09.02.09		DATA	09.02.09	LEGENDA SIMBOLI SYMBOLS LEGEND	SDN 25/30/35/45/65/85 SCR/SCN 35/45/65/85		230 Vac 50/60 Hz 050578-00	= +	FG. 3 F.T. 4	
					DISEGN.	R.GHIANI							
					VISTO	G.ROMAGNOLI							
REV.	MODIFICA	SG	DATA	FIRMA	APPR.	G.ROMAGNOLI	SOST. IL :	09.02.09	SOST. DA :	G.ROMAGNOLI	FILE :	05057800.DWG	00

0 1 2 3 4 5 6 7 8 9

